

FORD T-Mount HP Efficient Alternators

Features:

Fits FORD Chassis

Efficient

High Output

12V - 240A

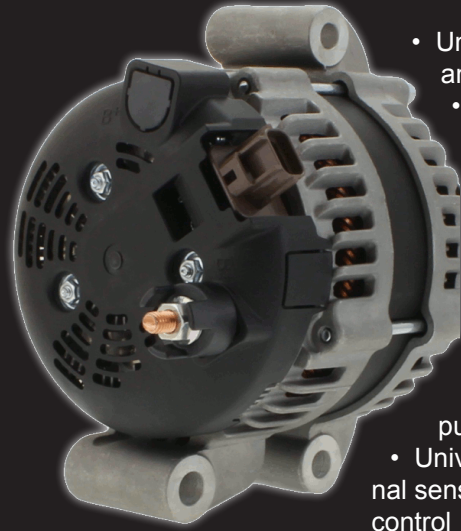

- Unmatched charging curve at idle - exceeding 170 amps
- Hair Pin, 6 phase stator maximizes slot fill
- OEM engineered to produce high output - this is not a "Pumped Up" auto unit
- 12 press fit 70A diodes with welded leads
- Unmatched heat recovery
- Super high heat bearings with 200+ degree seals and synthetic grease
- 96 slot stator compared to 36 slot provides superior efficiency
- Shaft design accepts passive, IDP, and OWC pulley designs
- Universal Regulator circuit adapts to internal or external sensing as well as PCM or ignition excitation with lamp control
- Unique rectifier design allows for 3 different output post positions

Typical HP Series Output Curve

RPM	1000	2000	3000	4000	5000
AMPS	6	173	217	235	242

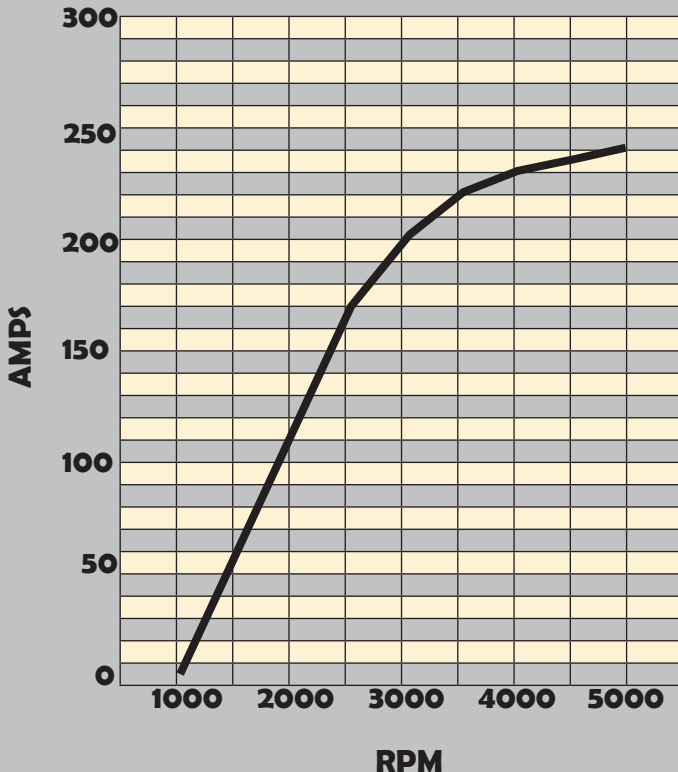

See the Difference?

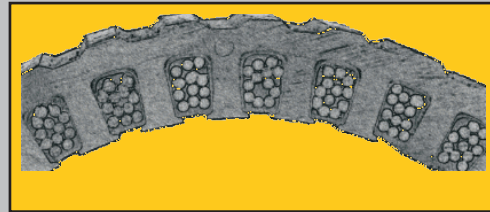

Round Wire Stator with Air Gaps
 Limiting the Slot Fill

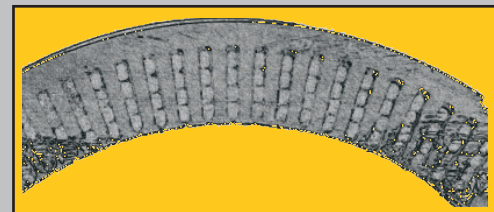

Hair Pin Stator with Solid Copper Maximized the Slot Fill and Copper to Steel Coupling

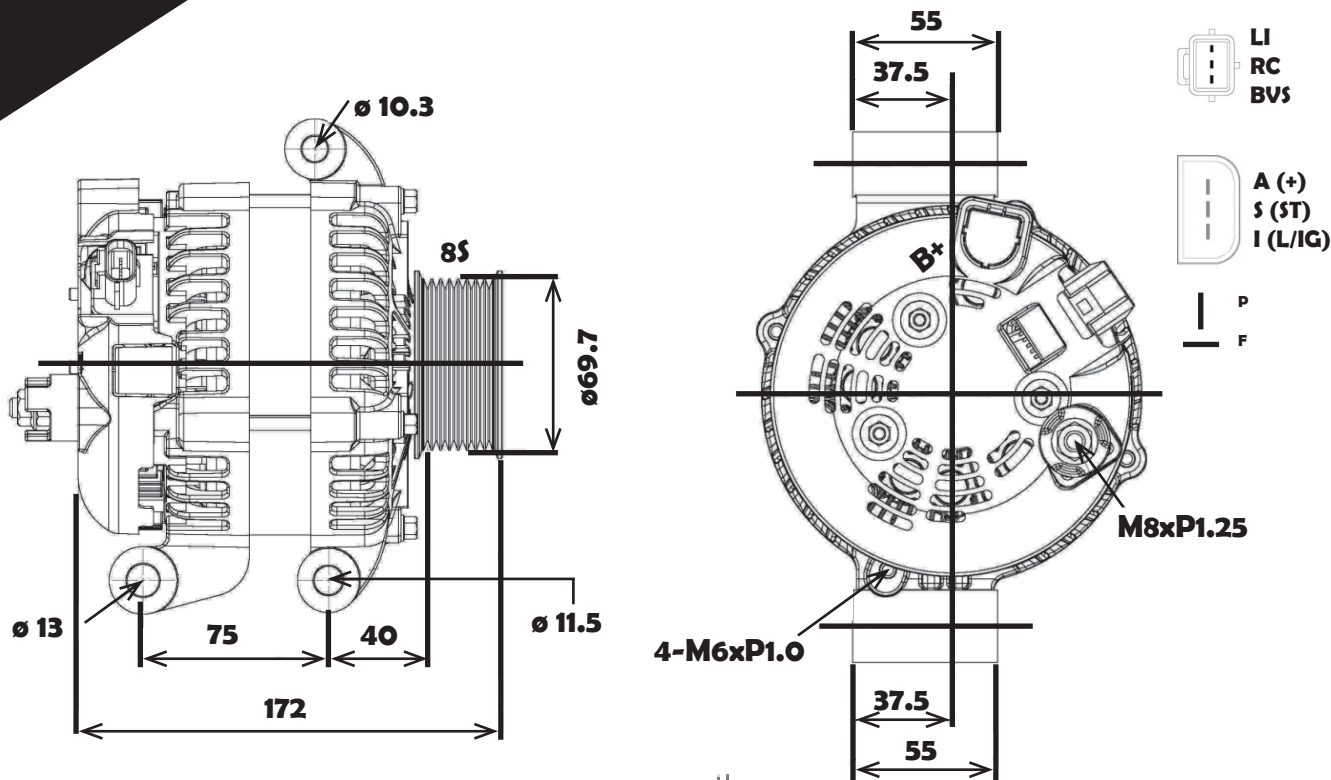

AVAILABLE OPTIONS

11290N

8G SERPENTINE PULLEY, SQ PLUG
 REPLACES: 104210-6100,02,03, 7C3T-1030-EE,
 7C3Z-10346-EA, AMP6103
 FITS: 2008-2010 F250/450 6.4L Diesel Engines

NOTE: Primary Unit in a Dual System

8253ND-240A

6G SERPENTINE PULLEY, SQ PLUG
 REPLACES: XF2U-10300-BC,BD, BE
 KARAM #:8253
 FITS: 1999-2003 FORD Windstar 3.8L Engine

NOTE: Replaces 6G

8307ND-240A

6G SERPENTINE PULLEY, 50-132392S HARNESS
 REPLACES: 3C3T-10300-BB, 3C3Z-10346-BA, 4C3T-10300-BB
 4C3Z-10346-BA, 6C2T-10300-DA, 6C2Z-10346-DA
 KARAM #: 8307
 FITS: 2003-2008 FORD F-SERIES SUPERDUTY
 6.0L V8 Diesel Engines

NOTE: Primary Unit in a Dual System

7750ND-240A

6G SERPENTINE PULLEY, D PLUG
 REPLACES: F07F-10300-AA, F07U-10300AA,AB,AC
 F07U-10346AC,BD, F57U-10300AA,BA, AL598HO,
 AL598N, AL598X
 KARAM #: 7750, 7792, 8258
 FITS: 1992-1997 FORD/MAZDA Car/Lt Truck
 with 2.3L, 3.0L, 4.0L, 5.0L & 5.8L Engines

7768ND-240A

8G SERPENTINE PULLEY, D PLUG
 REPLACES: F2PU-10346AF, F2TU-10300-AF, F3UU-10300-AF
 F37U-10300-AA, F3UZ-10346-A, F5UU-10300-BA
 F5UZ-10346-A, F6UU-10300-FA, F6UZ-10346-VA
 F85U-10300-AB, F8AZ-10346-AB, XL3U-10300-CB
 KARAM #: 7768, 7787, 7794, 8308, 12075
 FITS: 1992-2004 FORD PICKUP, SUV, VAN
 4.0L Engines and 7.3L Diesel Engines

PX520TND-240A

8G SERPENTINE PULLEY, EXTERNAL REGULATOR
 REPLACES: PENNTEX PX-520TD, PX525TD
 FITS: 1995-2004 FORD E-SERIES
 7.3L Diesel Engines

NOTE: Externally Regulated